

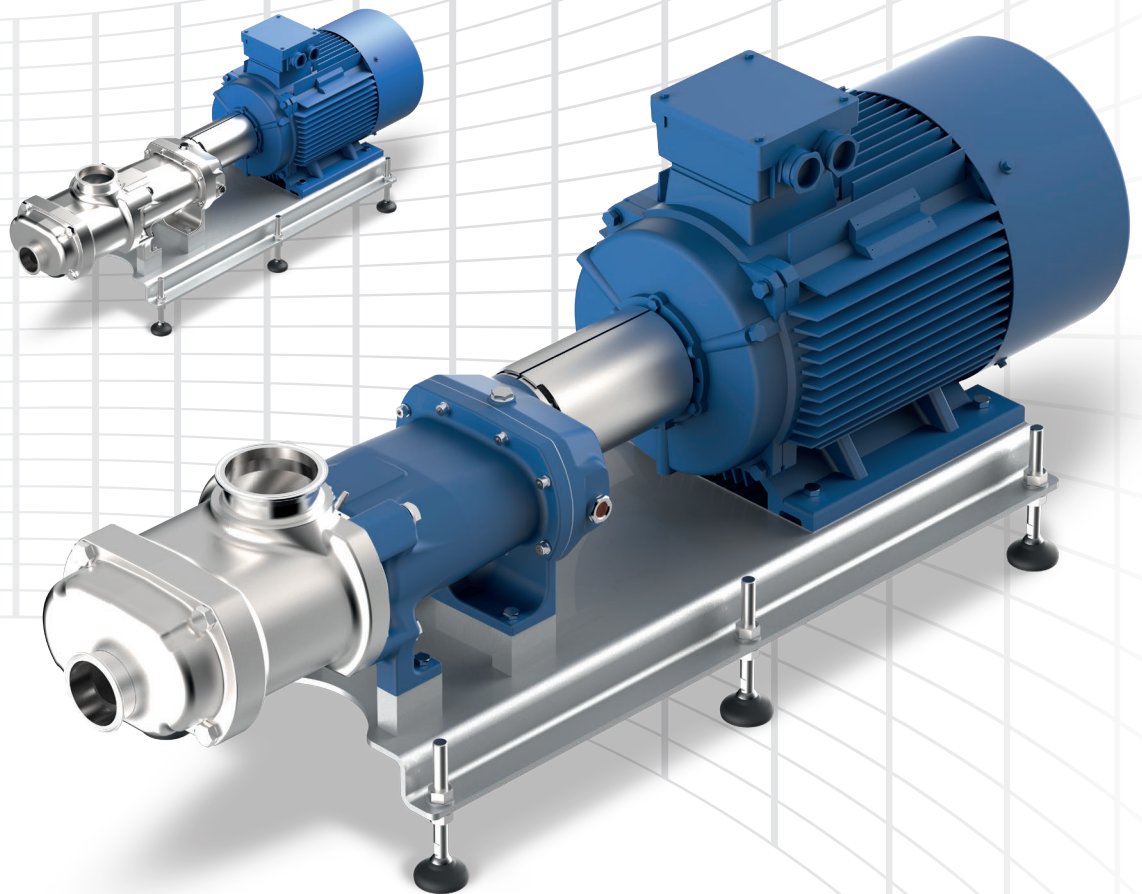

Twin Screw Pump  
**WANGEN Twin**



The hygienic solution for  
food, cosmetics and chemicals

Twin screw pump

## WANGEN Twin

With the WANGEN Twin, you can avoid time-consuming cleaning, frequent repairs, excessive wear or costly production stoppages. Thanks to the high quality materials and the sophisticated operating principle used, all these details will be a thing of the past. This is why the WANGEN Twin is the most economical solution for your needs.

Especially designed for use in the food and cosmetics industry, WANGEN has clever solutions that meet the strict hygiene regulations in these sectors. One of these solutions is the WANGEN Twin Screw Pump. It is part of the hygienic pumping solutions from WANGEN and was designed to reliably pump low to highly viscous, volatile or gaseous products and for applications where maximum hygiene and efficiency is required. The WANGEN Twin can be optionally heated for conveying special media.

Technical highlights:

Maximum flowrate 440.3 gpm

Maximum temperature +266 °F / +130 °C

Max. differential pressure 16 bar / 232 psi

Viscosity up to 1,000,000 cP



## Applications

# Conveying Materials

The following media can typically be conveyed with the WANGEN Twin Screw Pump in the food, cosmetic and chemical industries:

- Beverages such as direct juice, concentrates, mashes, pulp or yeast
- Dairy products such as yogurt, quark, cheese, pudding or butter
- Ketchup, mayonnaise, mustard, soup, gravy or salad dressings
- Confectionery, such as chocolate, fondant, liquid sugar syrup, sugar, rework or dough
- Fruits like strawberries
- Meat-based products such as minced meat, sausage meat or pet food
- Cosmetic products such as cream, ointment, soap or shampoo
- Chemical products such as raw chemical suspensions, antifreeze liquids, adhesives.



WANGEN Twin pumps in operation

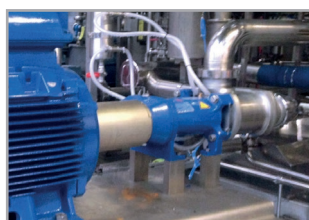

## Benefits

# Hygienic excellence

The WANGEN Twin achieves top marks for SIP and CIP cleaning. This is due mainly to the following unique characteristics of the WANGEN Twin used in this combination:

- Very high rotational speed range allows either product or cleaning fluid to be pumped as required
- High rotational speeds in cleaning operations ensure that the self-cleaning effect of the pump works
- High pressure up to 16 bar allows product-filled lines, equipment and fixtures to be emptied using cleaning fluid
- Produced according to the high hygiene specifications - EHEDG or 3A-certified manufacturing processes

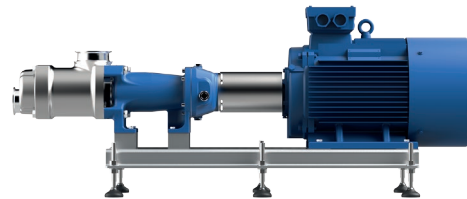

Benefits

## Two pumps in one - increased savings, more space

The WANGEN Twin can be used as a product and a CIP pump. After products have been conveyed with the WANGEN Twin, the pump can be filled with water and/or cleaning medium, then running the pump at a very high speed will clean it. In this way, cost savings for a separate centrifugal pump, bypass line, valves as well as the measuring and control technology required are achieved.

Using the WANGEN Twin for product transfer and CIP is an optimum solution to overcoming very restricted availability of space in the production area.

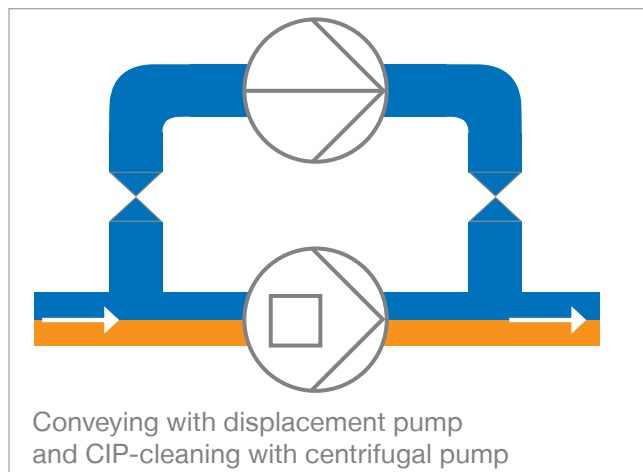
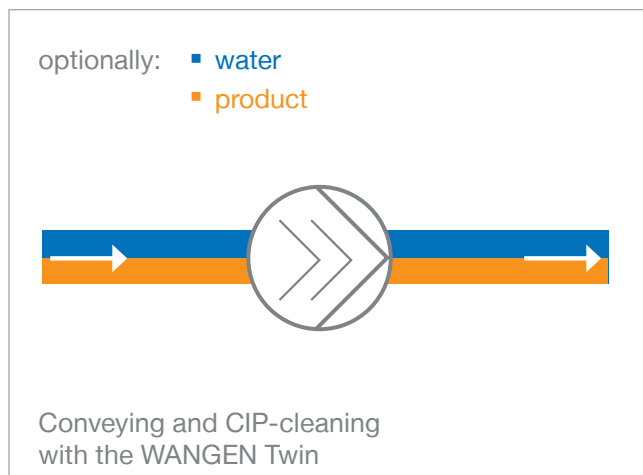
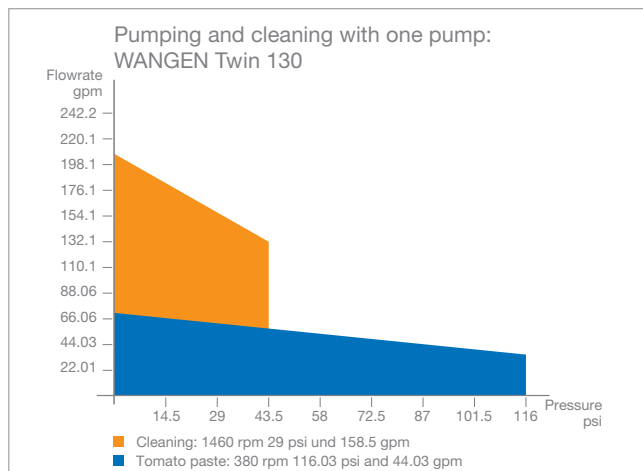

## Benefits

# Low Life-Cycle Costs

When buying a pump, we recommend that you consider the operating costs in addition to the initial procurement costs. Maintenance costs, production downtime costs and energy costs will all make a significant contribution to the overall costs.

A major advantage of our philosophy is clear here: To keep the total costs as low as possible throughout the complete life cycle, our approach is to keep service and maintenance to a minimum. This is possible thanks to the robust construction of our pumps, the high quality of the wearing parts and the low-wear design of every pump.

With each production disruption that you avoid, you will save not just the cost of spare parts, but also the costs of maintenance work and production downtimes. This not only saves you money, it also calms your nerves!

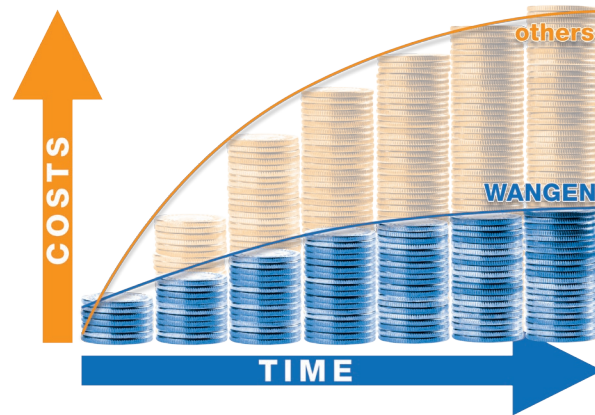

## Benefits

# Easy Maintenance

In general, WANGEN pumps have a very application and service-friendly design. This makes any maintenance work which is required simpler to carry out by yourself. For example, any wear due to the contact-free operation of the conveyor screws is confined to the bearings and the shaft seal.

The innovative, flexible sealing concept (see page 9) also helps to reduce costs and to increase plant use and availability. There is an economic choice of three possible seals. These can either be procured as a sealing package or separately. In this way, the choice of the seal material and its design has been made in an absolutely cost-optimised way.



### Simple manual cleaning

Thanks to the sophisticated design of the WANGEN Twin, manual cleaning is done in no time at all. This is due mainly to the following construction benefits:

- The entire pump casing can be removed by releasing only four screws
- All parts in contact with the product are then freely accessible for cleaning or inspection
- Individual elements and components can be easily separated from one another and connected up again

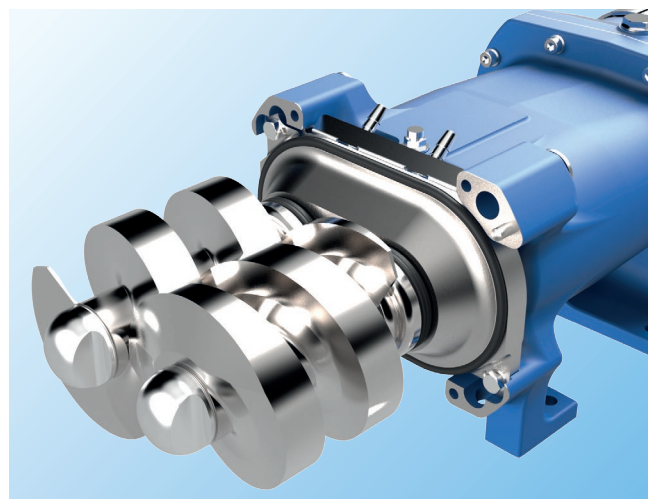

## Technical Data

# Design and Materials

In order to ensure the highest operating reliability, WANGEN pumps uses only the best raw materials for the respective purpose. Our many years of experience in the pumping of different media ensures a pump design which does justice to modern quality requirements.

- Materials in contact with product:  
Stainless steel AISI316L
- Surfaces in contact with the product:  
approx.  $RA < 0.8 \mu m$
- Ground and electro-polished surfaces (optional)
- Cleaning using CIP (= cleaning in place)  
and SIP (= sterilization in place)
- Elastomers conform to FDA and EC1935/2004  
requirements
- Constructed according to the EHEDG and 3A  
guidelines
- Wide variety of flange connections
- Flexible choice of drive units

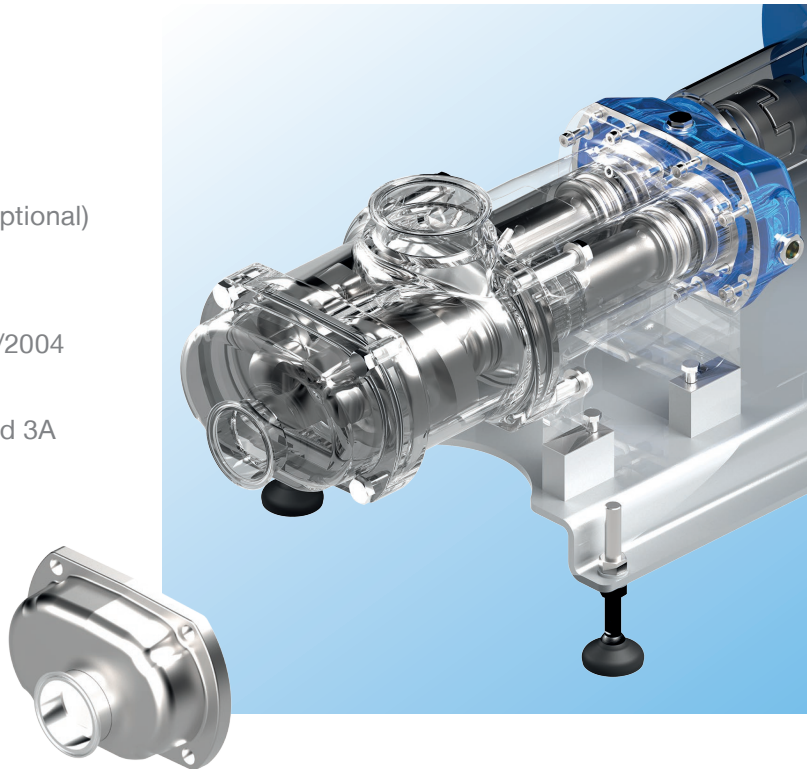

## Spare Parts

By using original spare parts from WANGEN AMERICA, we guarantee that the performance output of our pumps will be fully restored. With our decades of manufacturing competence, you will thus also be able to profit from our first class quality as a manufacturer and as a consequence ensure the long service life of your pump.





Technical Data

# Options and Accessories

You will find a wide range of accessories that complement our product range or can be adapted to suit your individual needs. Thus, you will be able to put together customised solutions. In this case too, we will also gladly advise you, as a number of individual solutions are possible.

- All types of hygienic fittings are available for the WANGEN Twin
- Base plate made of stainless steel A304, optionally with spherical feet (see figure on right)
- Surface-hardened feeder screws
- Cover over the drive unit (A304)
- Mobile versions with swiveling and fixed castors are available
- Bearing oil coolers for temperatures up to 302°F / 150°C
- Heating jacket on the pump casing
- Special designs suitable for adaptation to existing systems possible

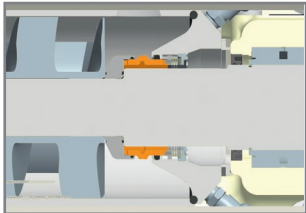
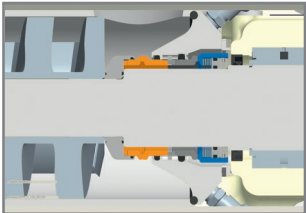

## Sealing concepts

Requirements:	Highest level of hygiene	Aseptic
Type of seal:	Single acting mechanical seal	Double acting mechanical seal
Material product side:	2 x silicon carbide or 2 x tungsten carbide	2 x silicon carbide
Material atmospheric side:	none	1 x carbon 1 x tungsten carbide
Location in the pump:	 <p>Mechanical seal on product side</p>	 <p>Mechanical seal on product side. Mechanical seal on atmospheric side</p>
Auxiliary seals:	FPM, EPDM, PTFE coated silicon ring	FPM, EPDM, PTFE coated silicone ring

## Technical Data

# Characteristics

### High suction performance

The axial conveyance and the low acceleration of the product in the pump enables excellent  $NPSH_R$  values < 2 m to be achieved.

- For emptying tanks
- With a low suction head to the pump
- For pumping viscous or low-boiling products

### Reversible conveying direction

Pumping in both directions is possible by reversing the rotational direction

- For pumping and subsequent emptying of the product line
- Use as a loading and unloading pump

### Wide viscosity range

Viscosities up to 1,000,000 cP possible by axial pumping and low amount of kneading work in the product. Good pump output thanks to high rotational speeds also with low viscosities with e.g. 0.5 cP.

- Pumping of all low to high viscosity products
- Pumping of different products using a single pump possible

### 60% gaseous share possible

The high speeds allow compressible products to be conveyed with the pump.

- For pumping and subsequent emptying of the product line
- Use as a loading and unloading pump

### Low pulsation

The axial pumping and low acceleration of product in the pump ensures low pulsation. Any product pulsation that develops could be reduced by increasing the speed of the pump.

- low shear forces maintains the structural and visual integrity of product ingredients
- ensures smooth conveyance of sensitive products
- For applications that require a high dosing precision
- It is possible to extend the pumping distance by installing a series of pumps



### Can run dry

The contact-free operation of the feed screws and a flushed / barrier mechanical seal make the pump completely insensible to dry running.

- Pump cannot fail even if the percentage of gas in the line is higher

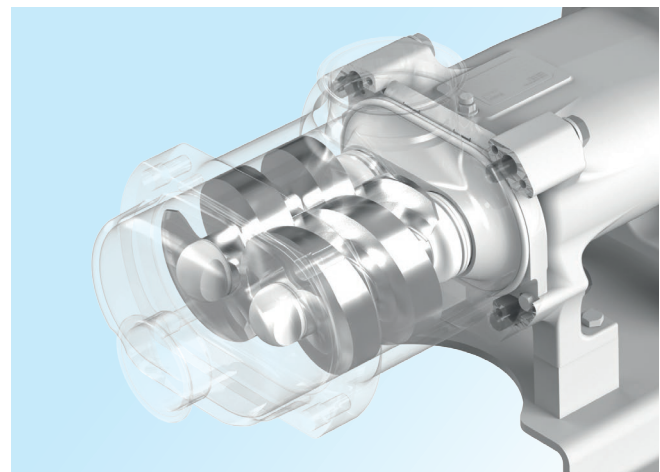

Technical Data

# Performance Data WANGEN Twin

Pump size	Maximum particle size (inch)	Maximum Flowrate (gpm)	Maximum differential pressure (bar / psi)
Twin 70	0.787	110.1 (at 4000 rpm)	16 / 232
Twin 104	0.984	264.2 (at 3600 rpm)	16 / 232
Twin 130	1.181	440.3 (at 3000 rpm)	16 / 232

Maximum temperature +266 °F (pumps for higher temperature on request),  
viscosity up to 1,000,000 cP.

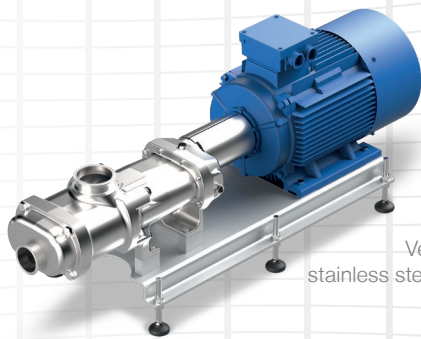

Version with stainless steel housing

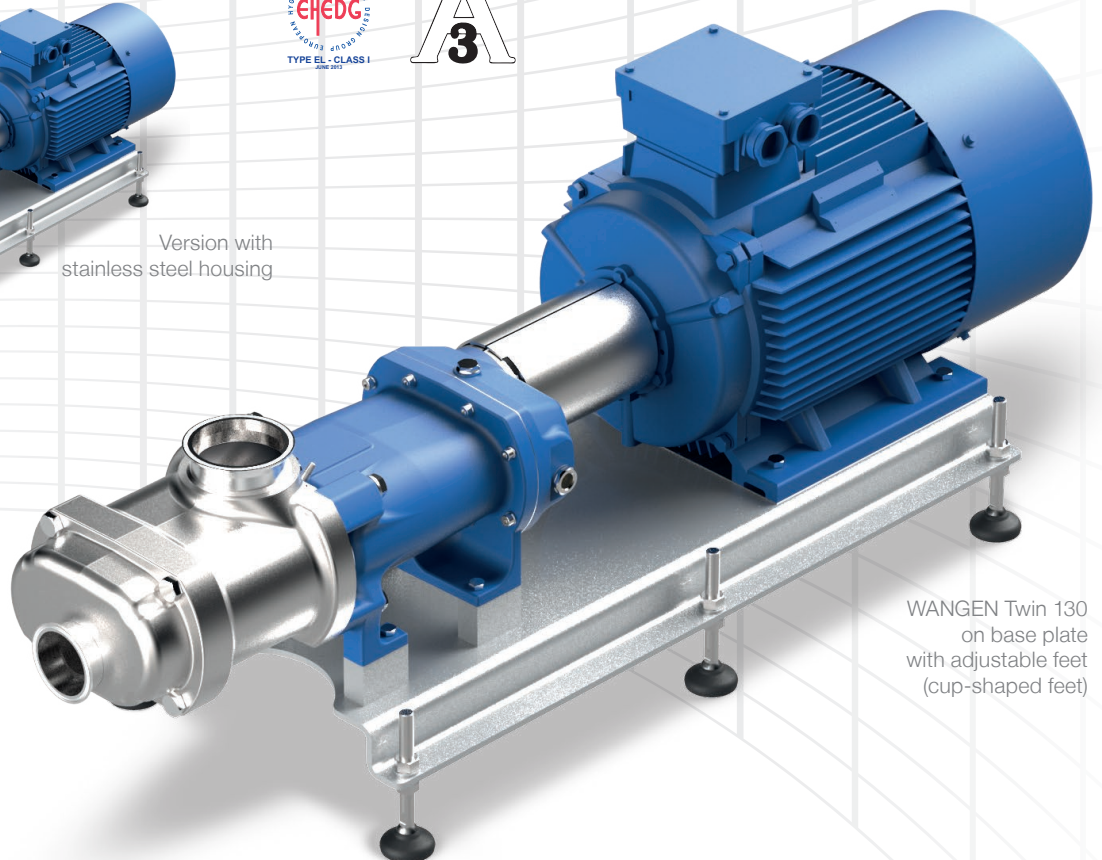

WANGEN Twin 130  
on base plate  
with adjustable feet  
(cup-shaped feet)

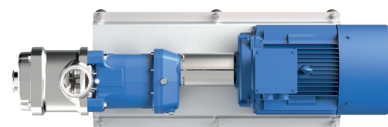
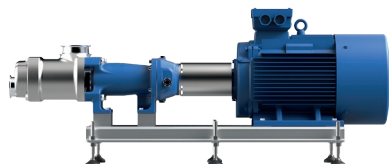



**Audited quality**

WANGEN PUMPEN quality management is certified to ISO 9001:2008.



**Tested sustainability**

WANGEN PUMPEN environmental management is certified to ISO 14001:2004.



Your next contact:

**Flowtrend, Inc.**

11512 Space Center Boulevard  
Houston, TX 77059  
+1 281 990 8582  
info@flowtrend.com  
www.flowtrend.com

**Wangen America Inc.**

855 N. Wood Dale Road,  
Suite A  
Wood Dale IL 60191  
USA

**Pumpenfabrik Wangen GmbH**

Simoniusstrasse 17  
88239 Wangen im Allg.  
Germany  
www.wangen.com